

# SALES & ENGINEERING DATA

## 66625X-XXX-C and 66627X-XXX-C 2" Metallic Diaphragm Pump

RATIO SERIES: **1:1**

FLUID P.S.I. RANGE: **10 - 120**

RELEASED: 3-21-06  
REVISED: 6-7-10  
(REV. 05) S-1362

### DIMENSIONAL DATA

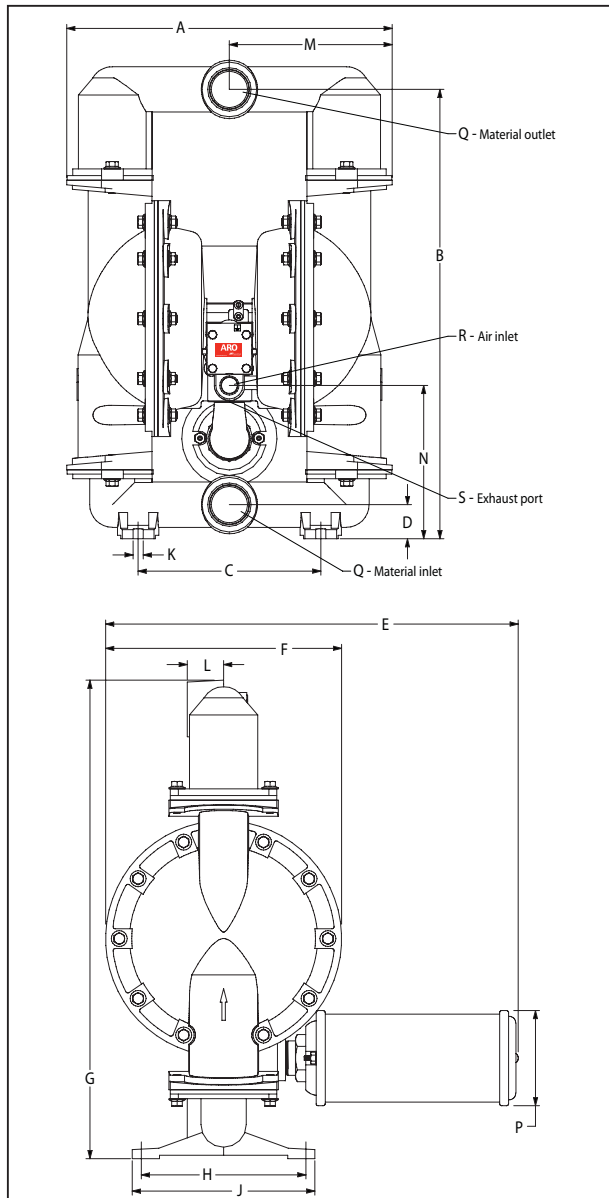

#### DIMENSIONS

- |                         |                         |                             |
|-------------------------|-------------------------|-----------------------------|
| A - see below           | G - see below           | N - 8-15/32" (214.6 mm)     |
| B - 24-3/4" (628.7 mm)  | H - 9-1/16" (230.2 mm)  | P - 5-1/4" (133.4 mm)       |
| C - 10-1/16" (255.6 mm) | J - 10-1/16" (255.6 mm) | Q - see below               |
| D - 1-7/8" (47.6 mm)    | K - 9/16" (14.3 mm)     | R - 3/4 - 14 NPTF - 2       |
| E - 22-3/4" (577.7 mm)  | L - see below           | S - 1-1/4 - 11-1/2 NPTF - 2 |
| F - 13" (330.2 mm)      | M - see below           |                             |

NOTE: Dimensions are shown in inches and (mm) and are supplied for reference only.

### SPECIFICATIONS

- Model Series** ..... 66625X-XXX-C / 66627X-XXX-C  
**Pump Type** ..... Metallic, air operated, double diaphragm pump  
**Ratio** ..... 1:1  
**Material Inlet / Outlet (female)**  
 66625X-XXX-C ..... 2 - 11-1/2 NPTF - 2  
 66627X-XXX-C ..... Rp 2 (2 - 11 BSP parallel)  
**Air Inlet (female)** ..... 3/4 - 14 NPTF - 2  
**Air Exhaust (female)** ..... 1-1/4 - 11-1/2 NPTF - 2  
**Weight** .... 6662X0-XXX-C ..... 65.15 lbs (29.55 kgs)  
 6662X1-XXX-C ..... 129.93 lbs (58.94 kgs)  
 6662X2-XXX-C ..... 124.30 lbs (56.38 kgs)  
 6662XA-XXX-C ..... 65.15 lbs (29.55 kgs)  
 6662XB-XXX-C ..... 129.93 lbs (58.94 kgs)  
 6662XC-XXX-C ..... 124.30 lbs (56.38 kgs)  
**Air Section Service Kit** ..... 637434  
**Fluid Section Service Kit** ..... 637432-XX

**6662XX - X[XX]- C**  
 637432 - [XX]  
 Diaphragm Material  
 Ball Material  
 EXAMPLE: Model #666250-1EB-C  
 Fluid Section Service Kit # 637432-EB

### PERFORMANCE

- Air Inlet Pressure Range** ..... 10 - 120 p.s.i.g. (0.69 - 8.3 bar)  
**Maximum Material Inlet Pressure**... 10 p.s.i.g. (0.69 bar)  
**Fluid Pressure Range** ..... 10 - 120 p.s.i.g. (0.69 - 8.3 bar)  
**Maximum Flow Rate (flooded inlet)** ... 172 g.p.m. (651.0 l.p.m.)  
**Displacement / Cycle @ 100 p.s.i.** ... 1.35 gal. (5.12 lit.)  
**Maximum Particle Size** ..... 1/4" (6.4 mm)  
**Maximum Temperature Limits (diaphragm / ball / seal / seat material)**  
 E.P.R. / EPDM ..... -60° to 280° F (-51° to 138° C)  
 Hytrel® ..... -20° to 150° F (-29° to 66° C)  
 Kynar® PVDF ..... 10° to 200° F (-12° to 93° C)  
 Nitrile ..... 10° to 180° F (-12° to 82° C)  
 Santoprene® ..... -40° to 225° F (-40° to 107° C)  
 PTFE ..... 40° to 225° F (4° to 107° C)  
 Viton® ..... -40° to 350° F (-40° to 177° C)  
**Noise Level @ 70 p.s.i. - 60 c.p.m.** ①... 85.3 db(A)②

- ① Tested with 94810 muffler assembly installed.  
 ② The pump sound pressure level has been updated to an Equivalent Continuous Sound Level (LAeq) to meet the intent of ANSI S1.13-1971, CAGI-PNEUROP S5.1 using four microphone locations.

### ACCESSORIES

66312 Air Line Connection Kit

Model	"A"	"G"	"L"	"M"	Model	"Q"
6662X0-XXX-C	17-15/16" (455.1 mm)	26-3/8" (669.0 mm)	2" (50.8 mm)	8-31/32" (227.6 mm)	666250-XXX-C	2 - 11-1/2 NPTF - 2
6662X1-XXX-C	18" (456.7 mm)	26-9/32" (667.5 mm)	1-7/8" (47.6 mm)	9" (228.4 mm)	666270-XXX-C	Rp 2 (2 - 11 BSP, parallel)
6662X2-XXX-C	17-15/16" (455.1 mm)	26-3/8" (669.0 mm)	2" (50.8 mm)	8-31/32" (227.6 mm)		
6662XA-XXX-C	17-15/16" (455.1 mm)	26-3/8" (669.0 mm)	2" (50.8 mm)	8-31/32" (227.6 mm)		
6662XB-XXX-C	18" (456.7 mm)	26-9/32" (667.5 mm)	1-7/8" (47.6 mm)	9" (228.4 mm)		
6662XC-XXX-C	17-15/16" (455.1 mm)	26-3/8" (669.0 mm)	2" (50.8 mm)	8-31/32" (227.6 mm)		

# PERFORMANCE CURVES

## 66625X-XXX-C / 66627X-XXX-C 2", METALLIC DIAPHRAGM PUMP

