

The main characteristic of VTS4 mixers is their four blades axial turbine. Axial turbine has a high power input ratio, and achieves a strong mixing effect in tanks from 4 to 15 m³ volume. Standard running speeds are 75 to 150 rpm. The rotation sense of the turbine can be easily changed just changing motor power feed wires. Thanks to their life greased reducer gear it is a friendly maintenance machine just to connect and run. VTS4 mixers can be equipped with more than one single turbine.

Main features:

- For tanks 4 – 15 m³
- Motor power: 0,37 kW to 2,2 kW.
- Running speed 75 to 150 rpm.
- 4 blades pitched axial turbine, diameters 400 to 800 mm.
- Shaft length up to 2500 mm.
- Shaft and propeller AISI 316, AISI 304, carbon steel, rubber coated.

Optional extras:

- AISI 316 or PVC plate with oil seal.
- Food industry execution, polished.
- ATEX motors.
- DIN or ANSI flanges.

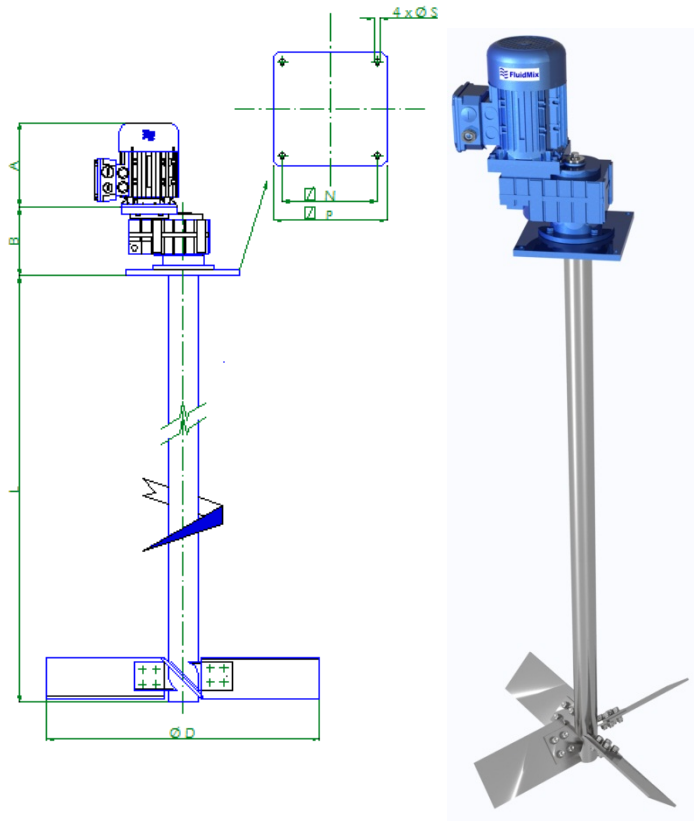

Model	Power kW	Speed rpm	A	B	D	L	N	P	S	Weight kg	Vol. * m ³
VTS4-02 02 C 00	0,25	107	187	174	400	2000	230	280	16	45	2
VTS4-03 02 C 01	0,37	96	207	174	500	2500	230	280	16	50	2 – 4
VTS4-05 02 C 02	0,75	96	224	181	600	2500	250	300	16	60	4 – 8
VTS4-07 02 C 03	1,5	99	274	213	700	2500	250	300	16	85	8 – 12
VTS4-08 02 C 04	2,2	99	309	213	700	1500	250	300	16	95	12 – 15

Dimensions in [mm].

(*) Tank volumes only for guidance.

Due to our policy of constant improvement, shown values can be changed.