

POMPE VERTICALI

VERTICAL PUMPS



ewv 20

ESPLOSO
EXPLODED VIEW

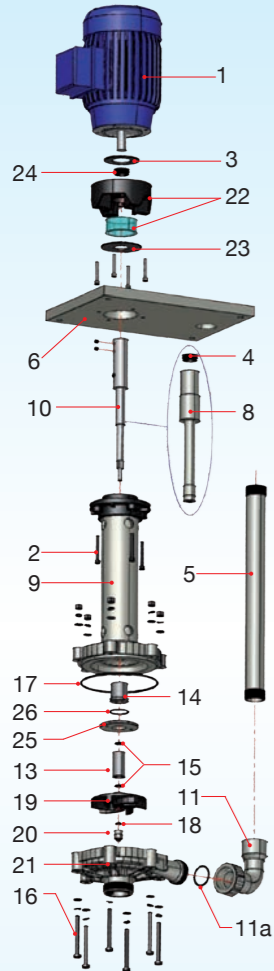

Descrizione particolari

1	Motore	15	O-Ring bussola
2	Viti	16	Viti corp. pompa
3	Deflettore	17	O-Ring corpo p.
4	Anello tenuta	18	O-Ring ogiva
5	Mandata	19	Girante
6	Piastra	20	Ogiva
8	Rivest. albero	21	Corpo pompa
9	Colonna	22	Lanterna
10	Albero	23	Deflettore
11	Gomito	24	Anello tenuta
11a	O-Ring gomito	25	Ghiera bussola
13	Bussola rotante	26	O-Ring ghiera
14	Bussola statica		

Part. description

1	Motor	15	Bush O-Ring
2	Screw	16	Pump housing bolts
3	Baffle	17	Pump housing O-Ring
4	Seal ring	18	Ogive O-Ring
5	Discharge pipe	19	Impeller
6	Support flange	20	Ogive
8	Shaft sleeve	21	Pump housing
9	Pump column	22	Vapour seal housing
10	Shaft	23	Baffle
11	Elbow	24	Seal ring
11a	Elbow O-Ring	25	Bushing nut
13	Rotating bush	26	O-Ring nut
14	Stating bushing		



DATI TECNICI

SPECIFICATION

	Portata max l/m	Prevalenza max m	Motore KW	IN/OUT D mm	T max esercizio °C	Peso Kg
	Maximum capacity l/m	Total head	Motor KW	IN/OUT D mm	T max exercise °C	Weight * Kg
50 Hz	370	17	1,1	50 x 40	PP = 75°C PVDF = 95°C	PP = 15,5 ÷ 19,5* PVDF = 18,5 ÷ 26,5
60 Hz	380	20	1,1			

* Può variare in conformità al motore utilizzato ed alla profondità della pompa.

* It changes according with motor supplier and pump depth.



POMPE VERTICALI

VERTICAL PUMPS

ewv 20

DIMENSIONI
DIMENSION

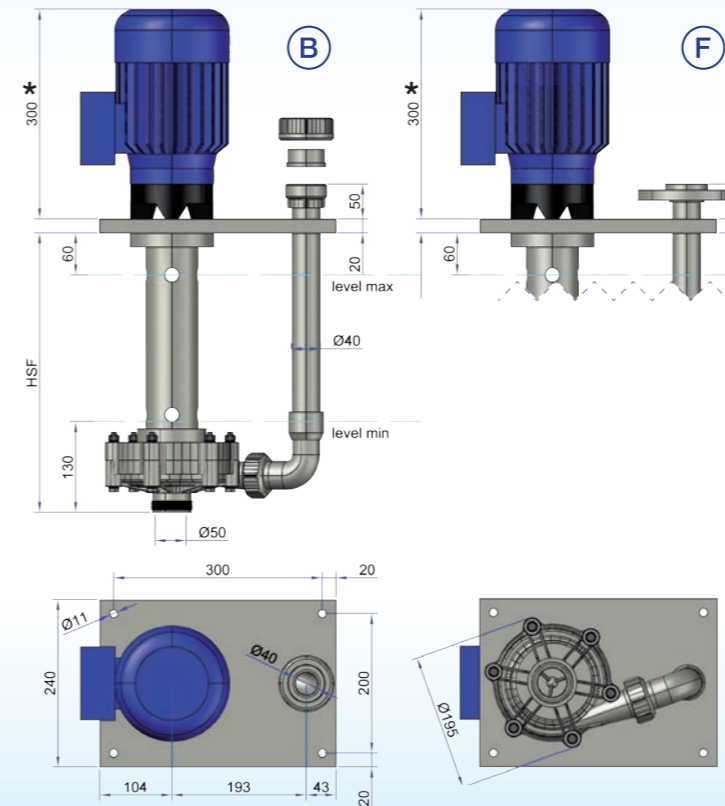

CURVE
PERFORMANCE

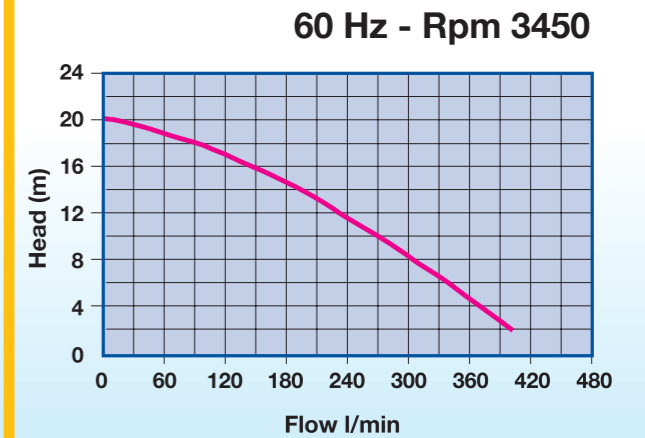
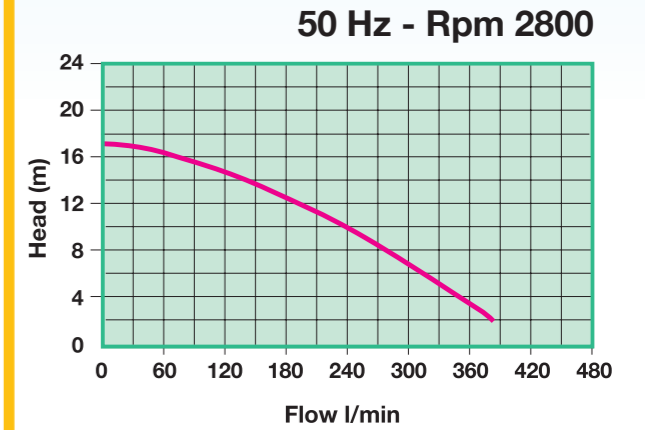

Riferimenti curve: acqua a temperatura ambiente
Curve references: water at room temperature

* Può variare in conformità al motore utilizzato

* It changes according with motor supplier

IDENTIFICAZIONE POMPA

PUMP IDENTIFICATION

Modello Model	Corpo pompa Pump body	Albero Shaft	Coppia di bussole statica/rotante Bushing couple static/rotating	HSF mm DEPTH mm	Attacchi Connections	Motore Motor	Optional Option
EWV20	P=PP F=PVDF	X= INOX AISI316 T= TITANIO TITANIUM H= HASTELLOY	1 = PTFE/PTFE 2 = PTFE/GRAFITE PTFE/CARBON 3 = PTFE/SIC 4 = GRAFITE/SIC CARBON/SIC 6 = GRAFITE/GRAFITE CARBON/CARBON	04 = 400 05 = 500 06 = 600 07 = 700 08 = 800 09 = 900 10 = 1.000 11 = 1.100 12 = 1.200 13 = 1.300 14 = 1.400 15 = 1.500	B= Bocchettoni Socket union F= Flangiati Flanged	A= 50HZ Rpm 2800 B= 60 HZ Rpm 3450	S= Succhieruola Strainer L= Lanterna Vapori Fume seal B= Bussola intermedia Additional bushing couple
EWV20	P	X	3	06	B	A	L